

MARBELLA
SUNSET





MARBELLA
SUNSET

←
*Life is better
with a terrace*

¿Por qué elegir Marbella Sunset para tu nueva casa?

Marbella Sunset es un innovador proyecto en Marbella formado por viviendas de uno, tres y cuatro dormitorios, apartamentos y áticos espaciosos y luminosos en los que empezar una nueva vida o disfrutar de momentos únicos en tus vacaciones en la **Costa del Sol**.

Las espectaculares **vistas al mar**, la localización en **primera línea de golf** y el **diseño de vanguardia** son tres poderosas razones para elegir **Marbella Sunset** para tu nuevo hogar.

El resto de la historia está en tus manos.

Why choose Marbella Sunset as your new home?

Marbella Sunset is an innovative project in Marbella consisting of one, three and four bedroom apartments and penthouses, spacious and bright, in which to start a new life or enjoy unique moments on your holidays on the **Costa del Sol**.

The **spectacular sea views**, the **frontline golf location** and **cutting-edge design** are three powerful reasons to choose **Marbella Sunset** for your new home.

The rest of the story is in your hands.

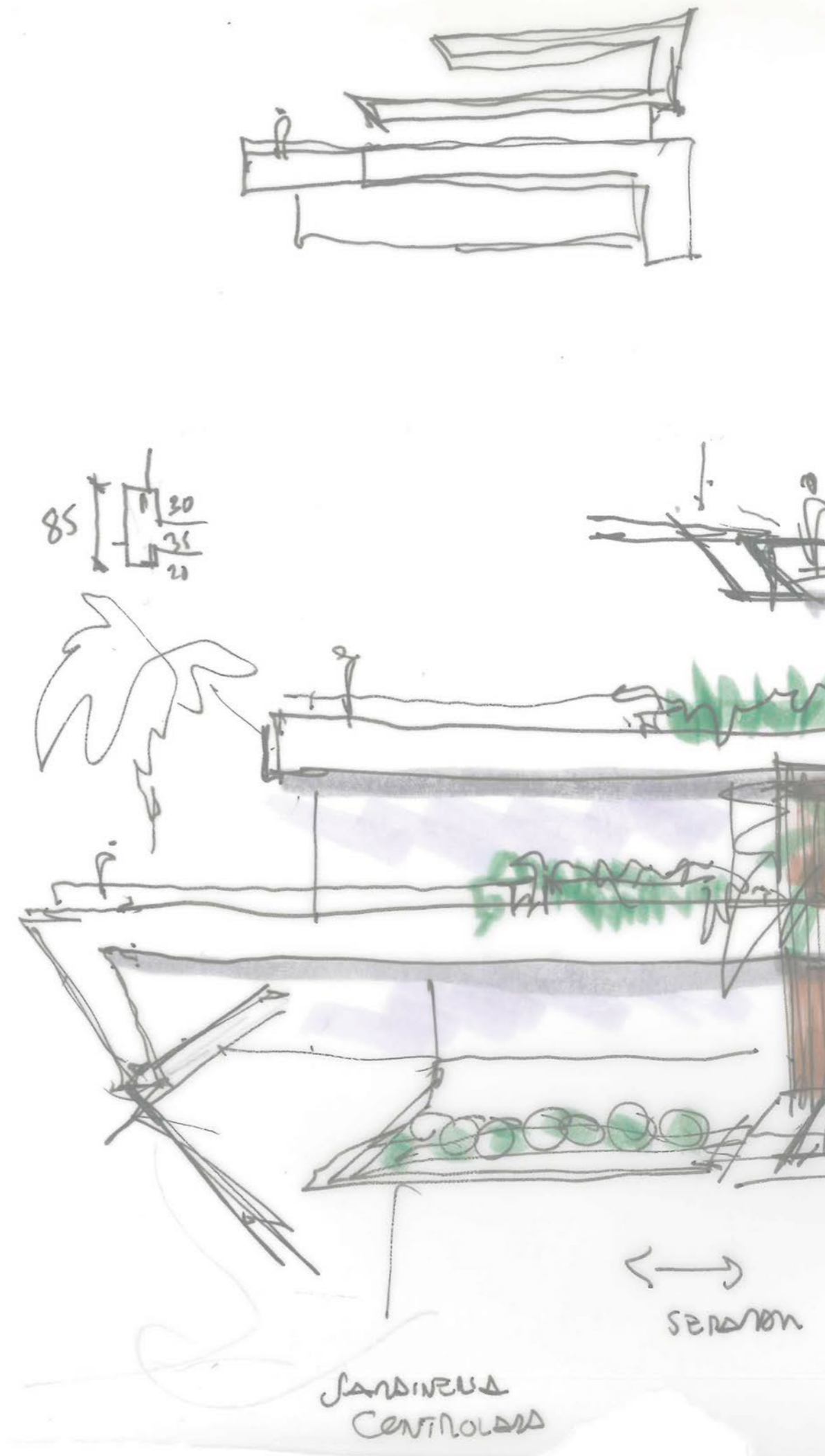

CEUSIAS →
MADERA → PANELES. (ELEGANCIA!)
PIEDRA → P. USA (MUNDO)



Cabopino (Marbella)

La zona de Cabopino, en Marbella, concentra todo lo que puedas desear. Al norte, pinares y Cabopino Golf con sus espectaculares vistas. Al sur, la zona natural protegida Dunas de Artola, que desemboca en la playa de Cabopino, un precioso y aislado arenal de arena dorada de unos 1.200 metros de longitud, junto al que encontrarás el puerto deportivo del mismo nombre.

The Cabopino area, Marbella, concentrates everything you could wish for. To the north, pine forests and Cabopino Golf with its spectacular views. To the south, the Dunas de Artola protected natural area, which flows into Cabopino beach, a beautiful and isolated beach of golden sand of about 1,200 meters in length, next to which you will find the marina of the same name.



El mar Mediterráneo, tu nuevo vecino

Seguro que siempre has soñado con vivir junto al Mar Mediterráneo. En Marbella Sunset ahora es posible. Por eso hemos ideado viviendas únicas de 1, 3 y 4 dormitorios, cada una con personalidad propia. Entre sus apartamentos y áticos encontrarás el que mejor se adapte a ti, espaciosos y luminosos para tu pleno bienestar.

The Mediterranean Sea, your new neighbour

Surely you have always dreamed of living by the Mediterranean Sea. At Marbella Sunset it is now possible. That is why we have designed unique homes with 1, 3 and 4 bedrooms, each with its own personality. Among its apartments and penthouses you will find the one that best suits you, spacious and bright for your full well-being.





Tu lugar en la Costa del Sol *Your place in the Costa del Sol*



Marbella: 14 km
Puerto Banús: 24 km
Estepona: 47 km
Málaga: 50 km



Málaga: 42 km
Gibraltar: 92 km
Granada: 156 km



Cabopino Golf: 750 m
Sta. María Golf Club: 4 km
Greenlife Golf: 5,5 km
La Siesta Golf: 6 km
Miraflores Golf: 7 km
Marbella Golf: 8,5 km



Hospital Costa del Sol: 10 km
Hospital Quirón (Marbella): 14 km
Hospital Xanit (Benalmádena): 33 km



Col. Platero Marbella: 4 km
Novaschool Calahonda: 5 km
Colegio bilingüe Las Chapas: 7 km
Colegio Ecos: 9 km



La Cañada Shopping: 14,5 km
Miramar shopping centre: 15 km
El Corte Inglés Mijas: 17 km
El Corte Inglés Puerto Banús: 24 km

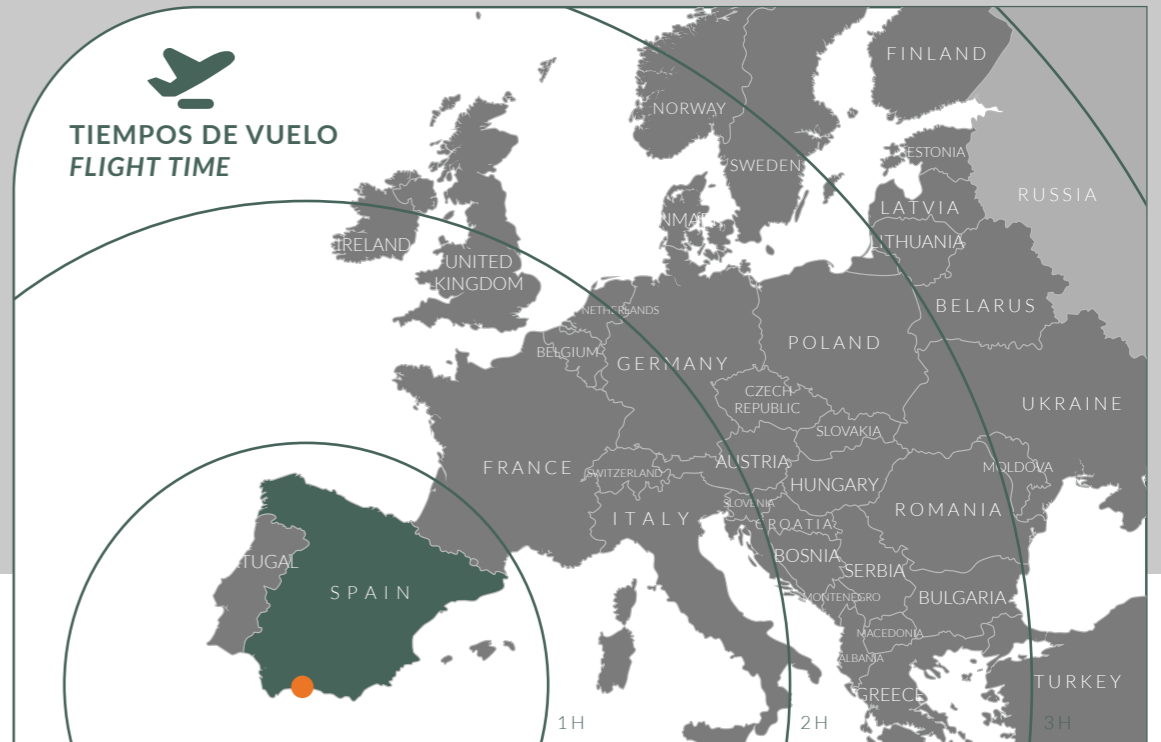

Un diseño para vivir en la naturaleza

Una excepcional ubicación, junto al mar Mediterráneo, con una temperatura media de 20 grados y más de 320 días de sol al año, 'La Costa del Golf' es una apuesta segura para aquellos aficionados y profesionales que quieran jugar en cualquier época del año. Además, si siempre habías soñado con despertarte viendo el mar, ahora tienes la oportunidad de alcanzar tus sueños.

Designed for natural living

This exceptional location by the Mediterranean Sea presents an average annual temperature of 20 degrees and over 320 days of sunshine a year. 'The Golf Coast' is thus a sure bet for both amateurs and professional golfers who want to practice at any time of the year. If you had always imagined yourself waking up to breathtaking views of the sea, this is your opportunity to finally find your dream house.

*Your moment
of the day →*





Two pool areas →





← Large
garden
areas

No lo sueñes, vívelo

Cada vivienda en Marbella Sunset es única, no hay dos iguales. Sin embargo, hay algo que todas tienen en común: el espacio es el protagonista. Por eso, los suelos de las estancias se funden con los de las terrazas, para crear una sensación de apertura hacia el mar y la montaña. Sus cocinas integradas invitan a compartir desayunos, cenas, sobremesas... Todo pensado para seguir creando recuerdos.

Don't dream it, live it

Each home in Marbella Sunset is unique, no two are alike. However, there is something they all have in common: space is the protagonist. For this reason, the floors of the rooms merge with those of the terraces, to create a sense of openness towards the sea and the mountains. Its integrated kitchens invite you to share breakfasts, dinners... All thought to continue creating memories.

*Chill and
relax*
↘





GRANDES VENTANALES ENRASADOS CON EL SUELO, PARA CREAR UNA SENSACIÓN DE CONTINUIDAD ENTRE LAS ESTANCIAS Y LA GRAN TERRAZA.

LARGE WINDOWS AT GROUND LEVEL, TO CREATE A SENSE OF CONTINUITY BETWEEN THE ROOMS AND THE LARGE TERRACE.





*Here, your
future terrace*



Apartamentos creados con alma de villas

El exterior de Marbella Sunset combina la elegancia de la madera y el cristal con la robustez de la piedra. Su diseño aprovecha el desnivel del terreno para crear viviendas únicas y diferentes: bajos con jardines privados, áticos con espectaculares terrazas y piscina privada, apartamentos de 1, 3 y 4 dormitorios...

Sin duda, aquí encontrarás tu nuevo hogar.

Apartments created with the soul of a villa

The exterior of Marbella Sunset combines the elegance of wood and glass with the robustness of stone. Its design takes advantage of the unevenness of the land to create unique and different homes: ground floors with private gardens, penthouses with spectacular terraces and private pool, 1, 3, and 4 bedroom apartments...

Without a doubt, you will find your new home here.





DISEÑOS EXTERIORES PENSADOS PARA ENAMORAR, ASÍ COMO PARA APROVECHAR AL MÁXIMO LA LUZ DEL MEDITERRÁNEO

OUTDOORS DESIGNS CREATED TO MAKE YOU FALL IN LOVE AND MAKE THE MOST OF THE MEDITERRANEAN LIGHT

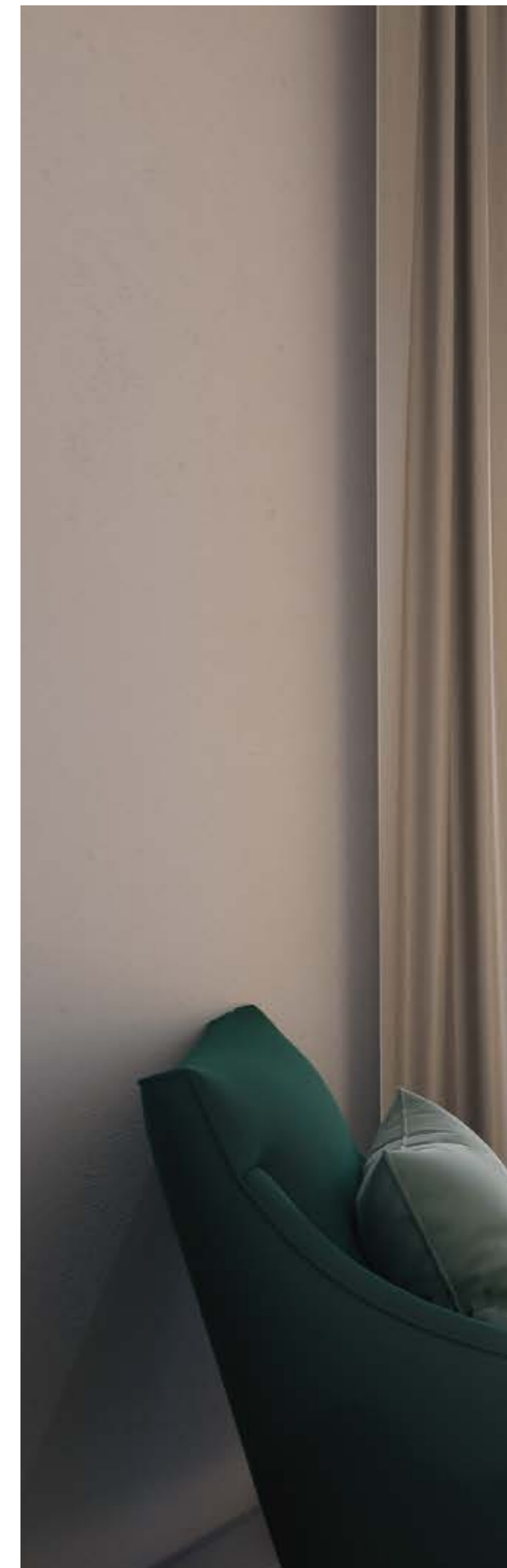







Un diseño único, un entorno inigualable

Su configuración, con varias alturas, está pensada expresamente para que la luz del Mediterráneo inunde cada una de las viviendas. En las zonas comunes, el agua de sus dos piscinas y la vegetación de sus muchas zonas ajardinadas se funden en una mezcla perfecta que invita a relajarse y disfrutar.

A unique design, an unbeatable environment

Its configuration, in different heights has been expressly designed so that the light of the Mediterranean flows through each of the houses. In the common areas, the water of its two swimming pools and the vegetation of its many garden areas merge perfectly inviting you to relax and enjoy.





Arquitectos

ISMAEL MÉRIDA ARQUITECTOS son los encargados del diseño de Marbella Sunset. El estudio desarrolla su trabajo principalmente en el ámbito residencial, arquitectura del ocio, arquitectura de autor, interiorismo y paisajismo, cuidando hasta el último detalle ...

El estudio forma un equipo con el equilibrio como su pilar central y con la experiencia de sus ingenieros y técnicos, el trabajo joven y la intensidad en su diseño como grandes bazas.

The architects

ISMAEL MÉRIDA ARQUITECTOS carries out its work primarily in the areas of residential, architecture of leisure, author architecture, interior design and landscaping... coming to the last detail...

They are a team where balance is the central pillar: experienced engineers and technicians combined with youthful work and intensity in their design.

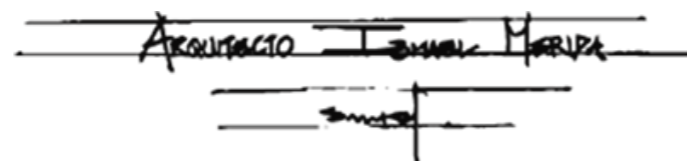

www.ismaelmerida.com



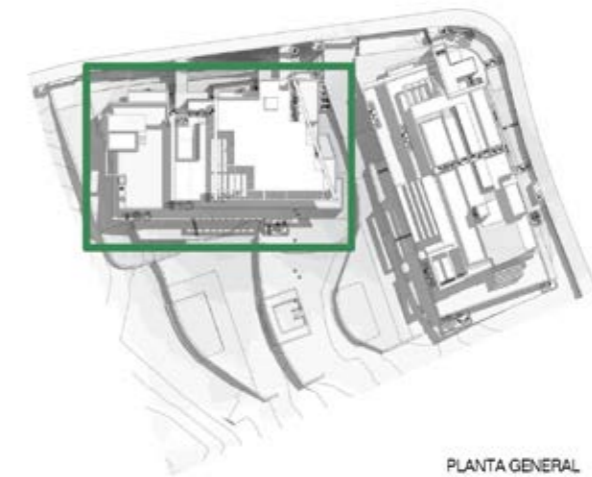

PLANTA GENERAL



Planos

Bloque 3-4, nivel 1, vivienda 12
Block 3-4, level 1, apartment 12

SUPERFICIES CONSTRUIDAS / BUILT AREA:

Vivienda / Apartment	Porche / Porch	Terraza / Terrace	Jardín / Garden
160,15 m ²	51,13 m ²	19,16 m ²	0,00 m ²

SUPERFICIES ÚTILES / USABLE AREA:

Vivienda / Apartment	Porche / Porch	Terraza / Terrace
114,95 m ²	48,09 m ²	16,07 m ²

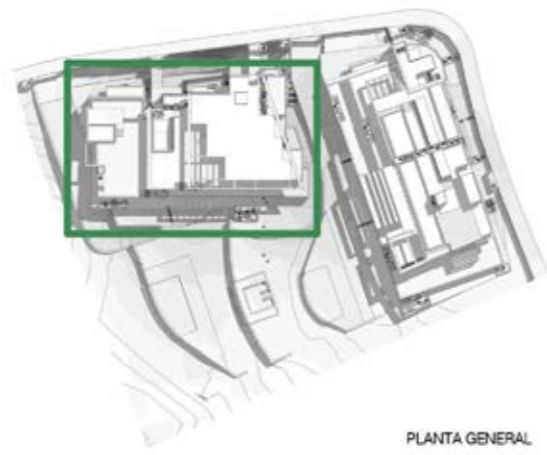

PLANTA GENERAL

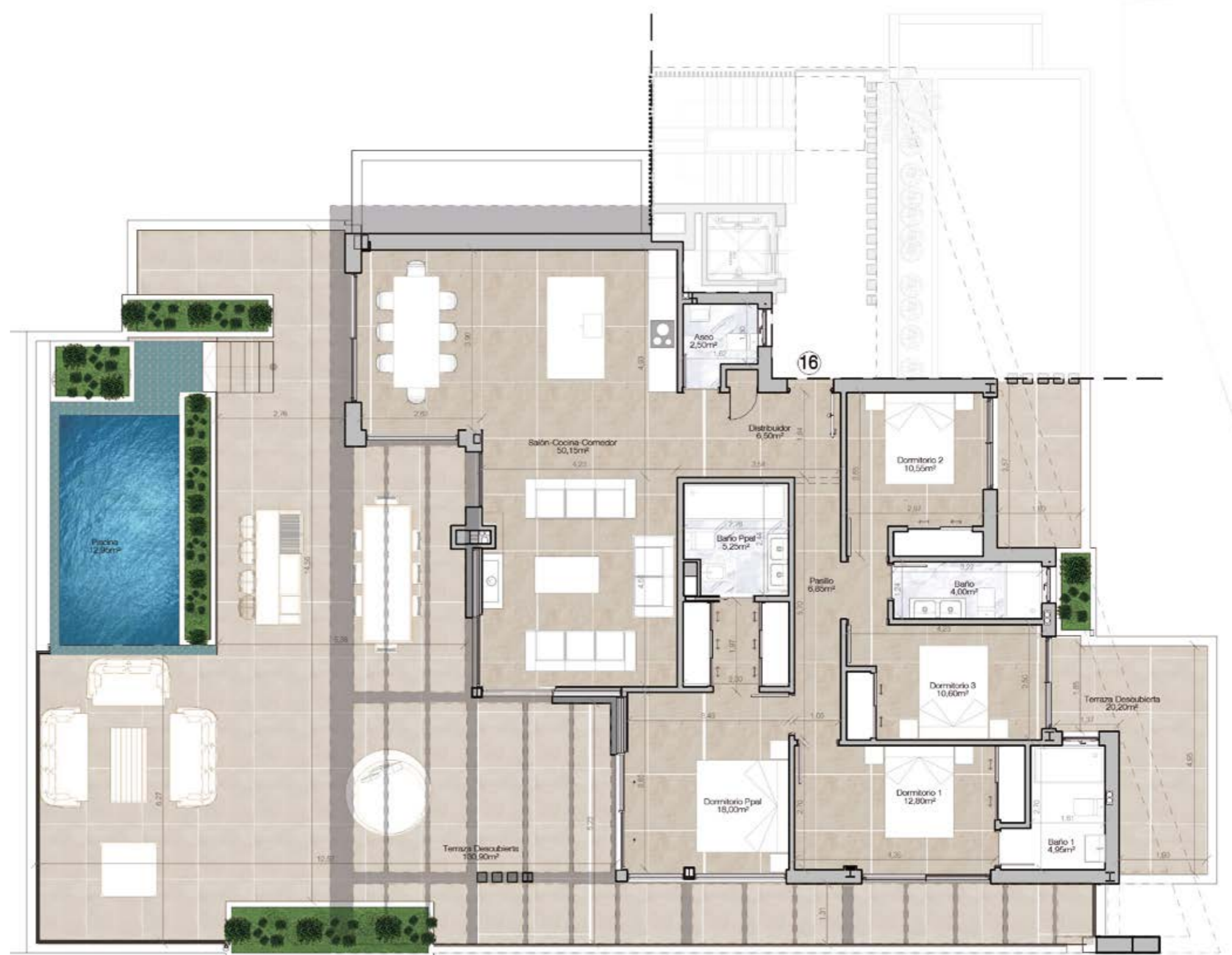

Plans

Bloque 3-4, nivel 3, vivienda 16
 Block 3-4, level 3, apartment 16

SUPERFICIES CONSTRUIDAS / BUILT AREA:

Vivienda / Apartment	Porche / Porch	Terraza / Terrace	Jardín / Garden
191,09 m ²	0,00 m ²	189,19 m ²	0,00 m ²

SUPERFICIES ÚTILES / USABLE AREA:

Vivienda / Apartment	Porche / Porch	Terraza / Terrace
132,11 m ²	0,00 m ²	160,81 m ²

This document is informative and may experience variations due to the technical requirements of the project. All the furniture, including that of the kitchen, is merely informative. The turns of the doors and the distribution of sanitary ware are not binding. The surfaces expressed here are approximate, and may undergo modifications for technical reasons in the development of the execution of the works. The surfaces indicated are calculated in accordance with Decree 218/2015 on consumer information on the sale and rental of homes in Andalusia.

Hogares inteligentes y más eficientes

En Marbella Sunset, la domótica tiene un papel fundamental. Y es que, si hoy en día la tecnología lo abarca todo, ¿por qué no aprovechar sus ventajas también para nuestra casa? Las ventajas de utilizar el control inteligente de nuestros hogares son muchas, desde ahorrar de manera real en el consumo de energía hasta aumentar la seguridad, pasando por un mayor bienestar para nuestra familia.

Smart and more efficient homes

In Marbella Sunset, home automation plays a key role. And, if technology encompasses everything today, why not take advantage of its benefits for our home as well? The advantages of using the intelligent control of our homes are many, from really saving in energy consumption to increasing security, to greater well-being for our family.



Calificación energética en trámite
Energy certificate pending

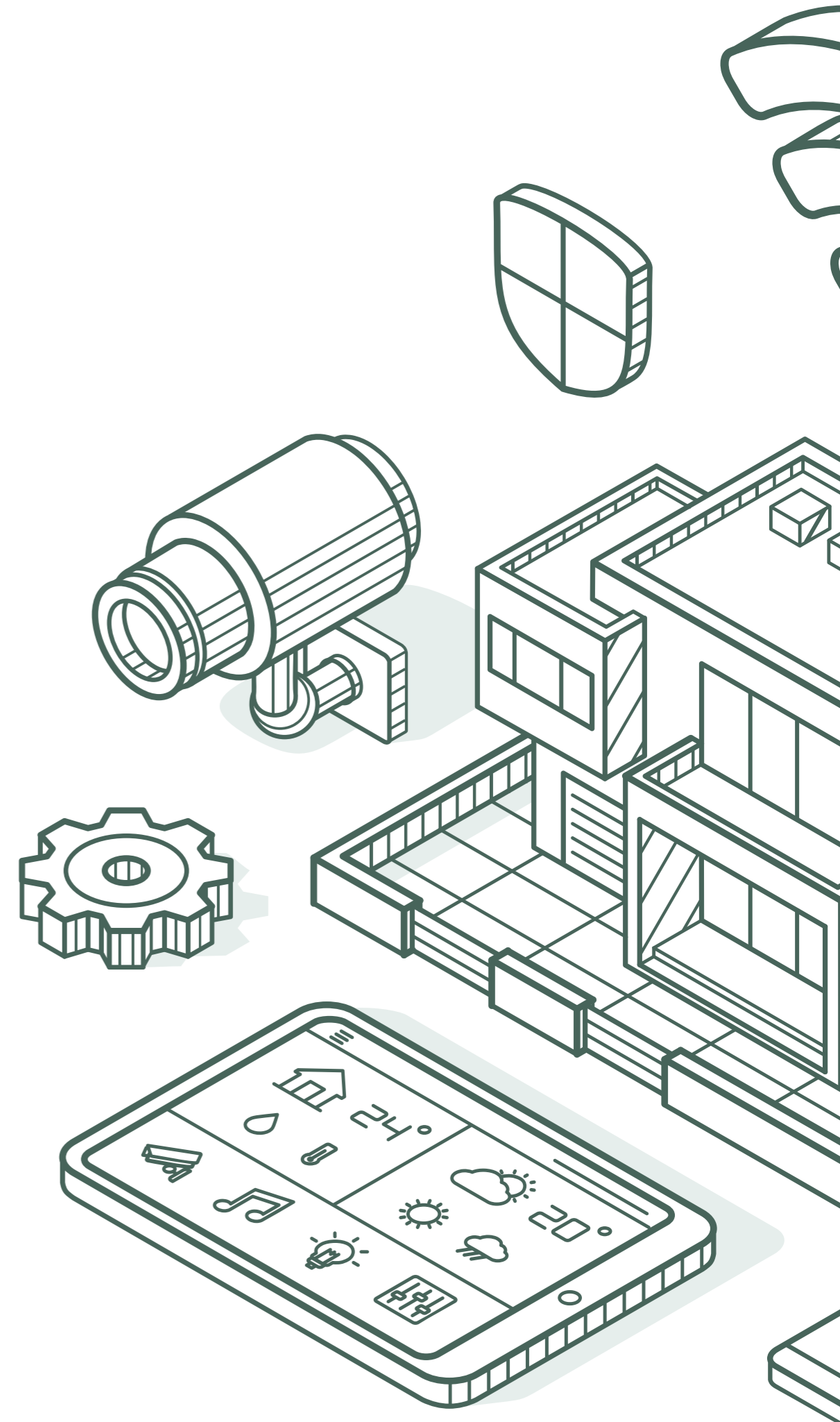

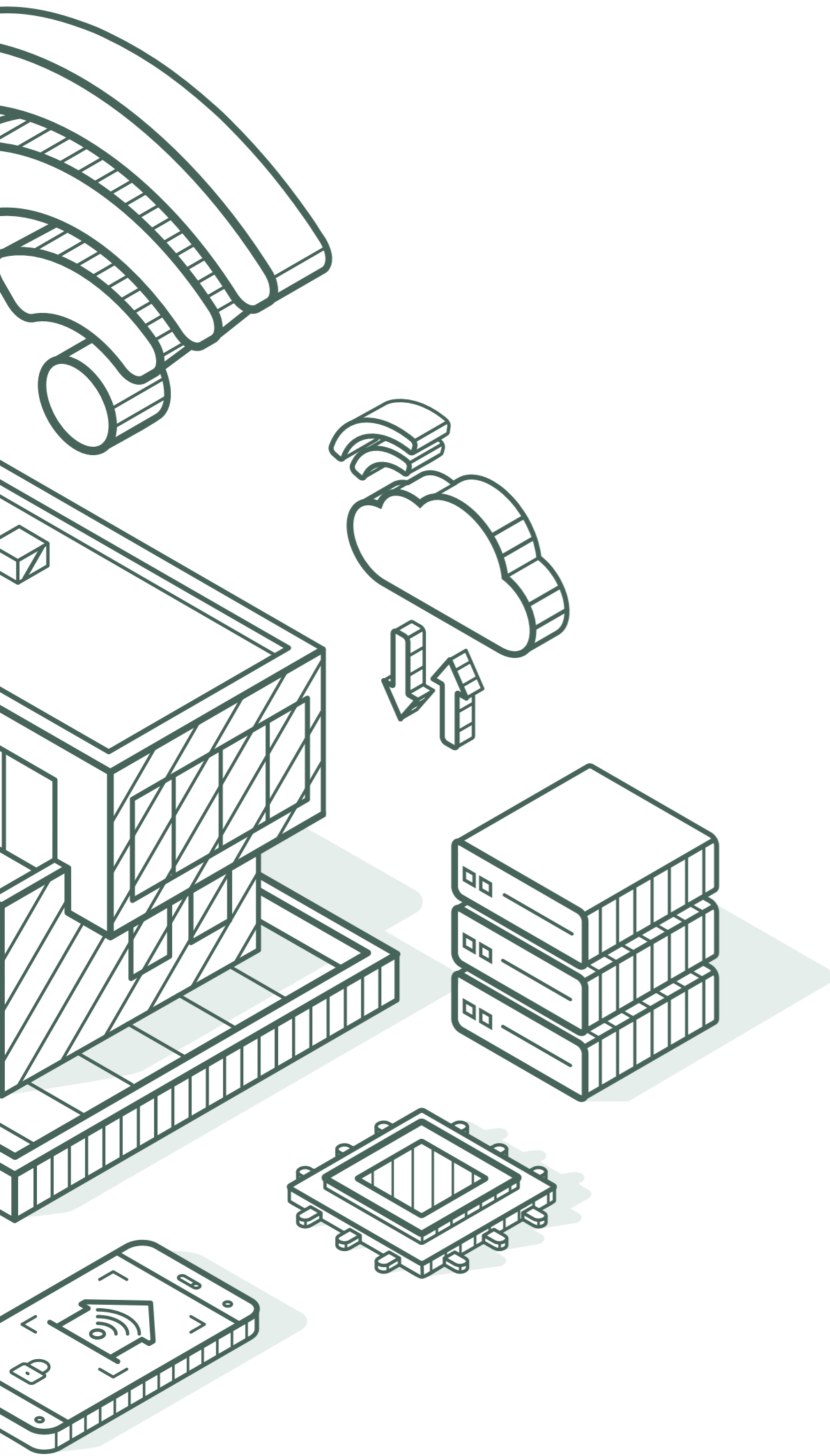



Marbella Sunset cuenta con instalación de Domótica Koolnova para toda la vivienda, incluyendo:

Koolnova home automation system for the whole house, including:

- 

Control de toda la iluminación en salón y dormitorio principal.
Control of all lighting in living room and master bedroom.
- 

Apagado general de toda la vivienda.
General off-switch for the whole house.
- 

Apagado centralizado de persianas eléctricas.
Centralised switch-off for electric window blinds.
- 

Sensor de agua en zonas húmedas.
Flood-sensor in wet-areas.
- 

Sensor de humos en cocina.
Smoke-detector in kitchen.
- 

Pantalla de visualización y control en entrada a la vivienda.
Viewing screen and control at house entrance.
- 

Control de toda la instalación desde smartphone, tablet o el ordenador.
Control of the whole installation via smartphone, tablet or computer.
- 

Control de climatización zonificado.
Zoned climate control.



Comercializado por: / Commercialised by:



Promueve: / Developed by:



Información: / More information:

+34 951 100 077

info@primeinvest.es